

# Diagram A

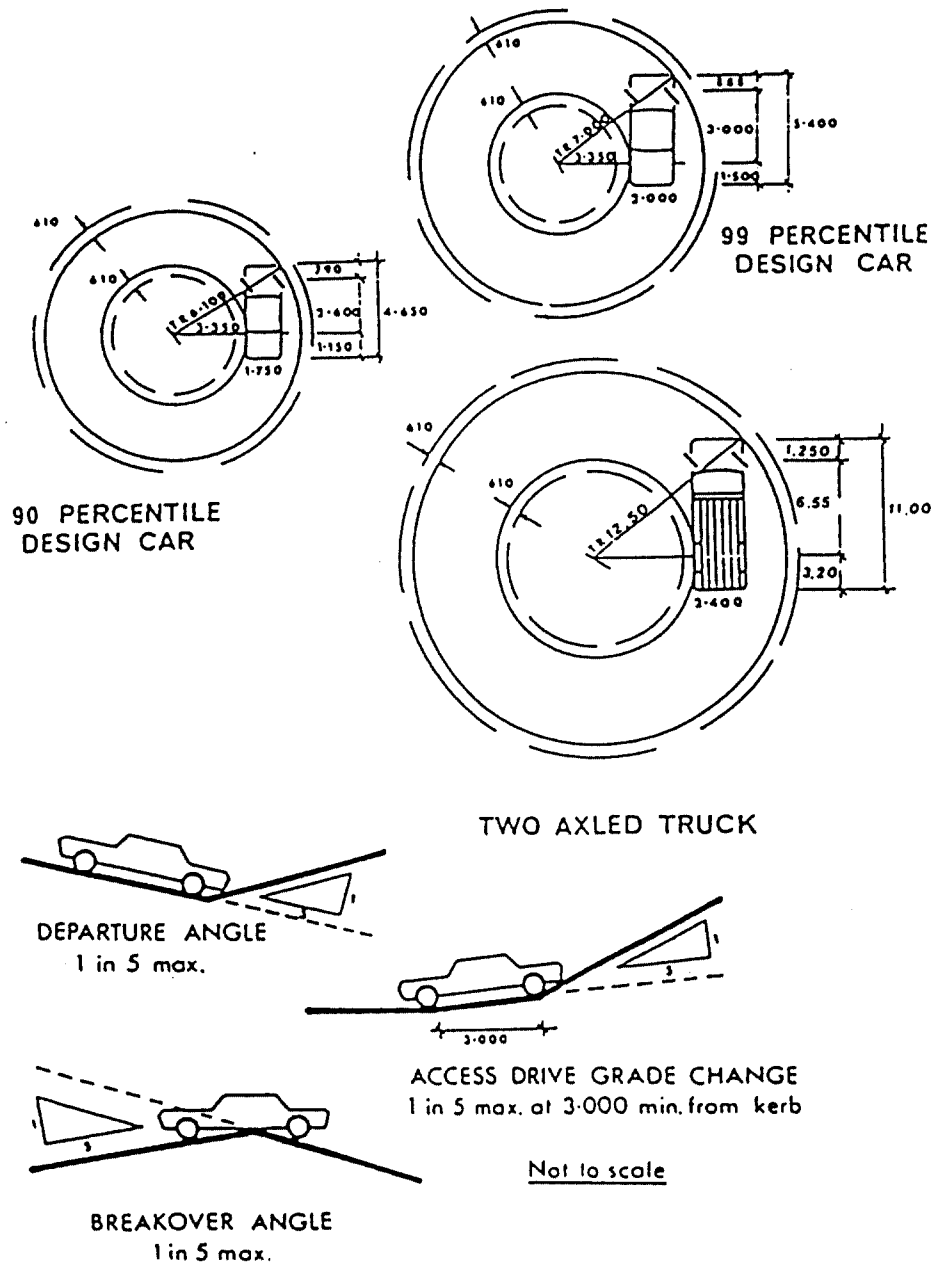

90 & 99 PERCENTILE DESIGN MOTORCARS &  
90 PERCENTILE DESIGN TWO AXLED TRUCK

Diagram B

# Standard Car Park Dimensions

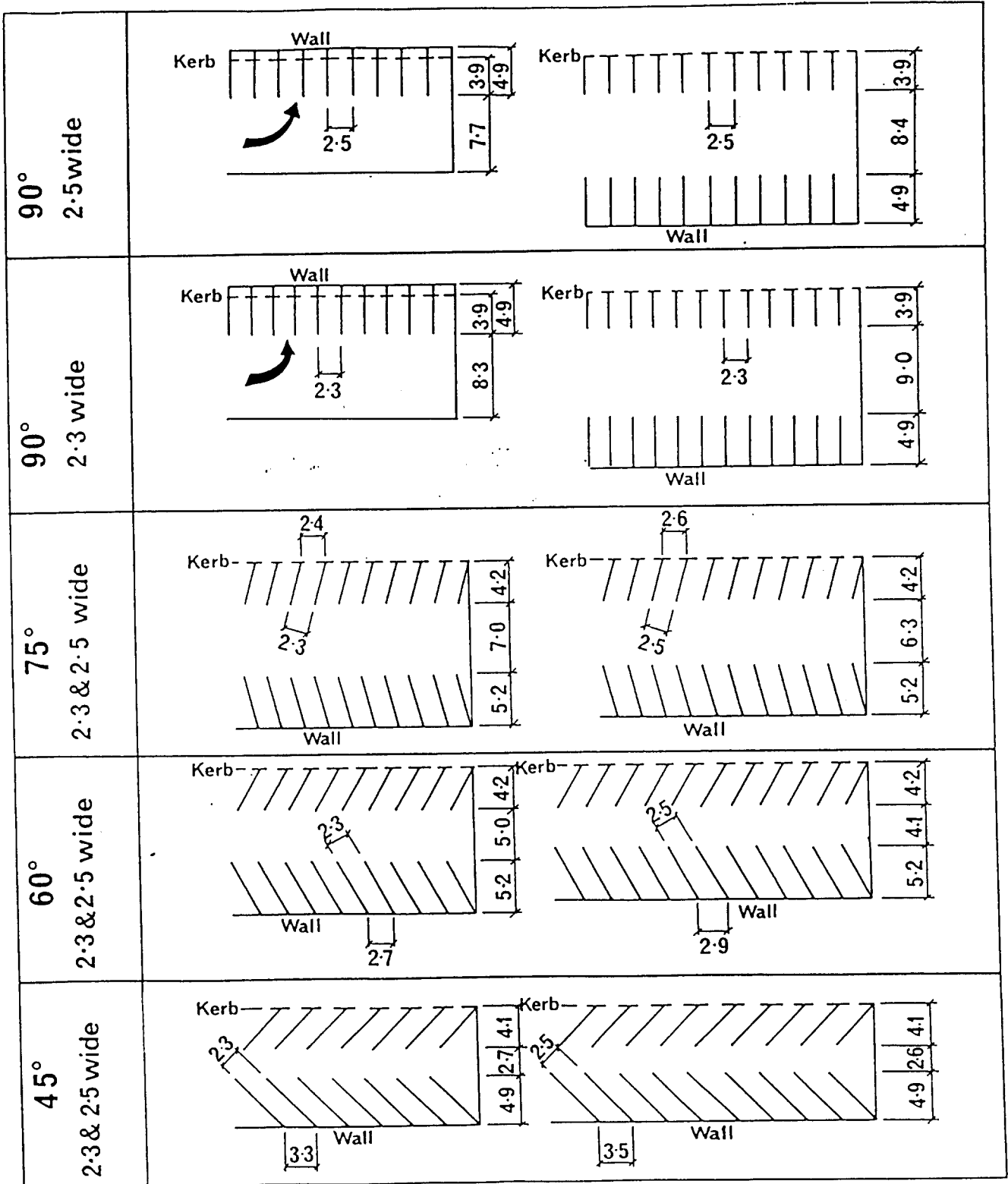

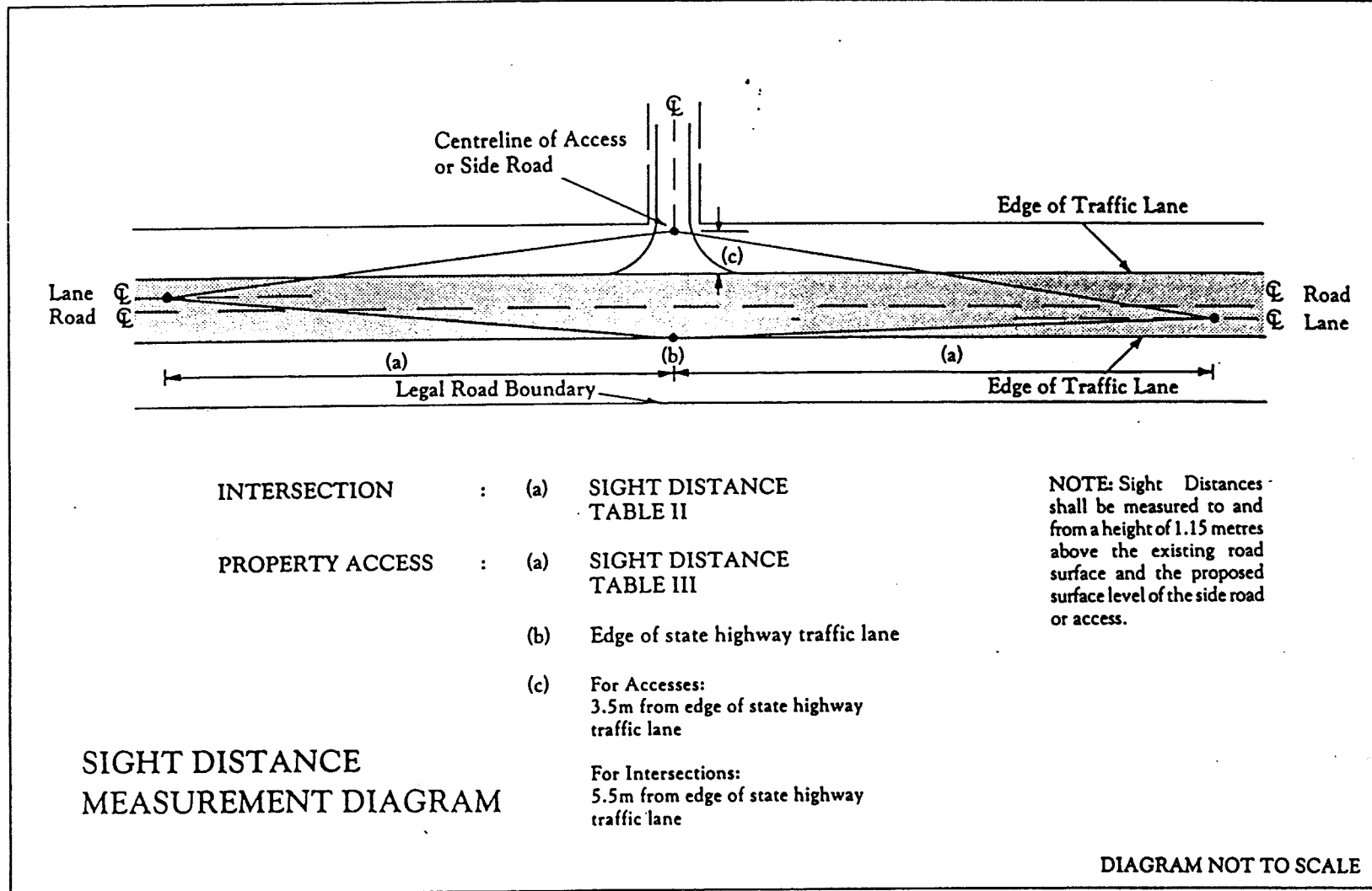

**Diagram 1**

: PARKING LOADING AND ACCESS.

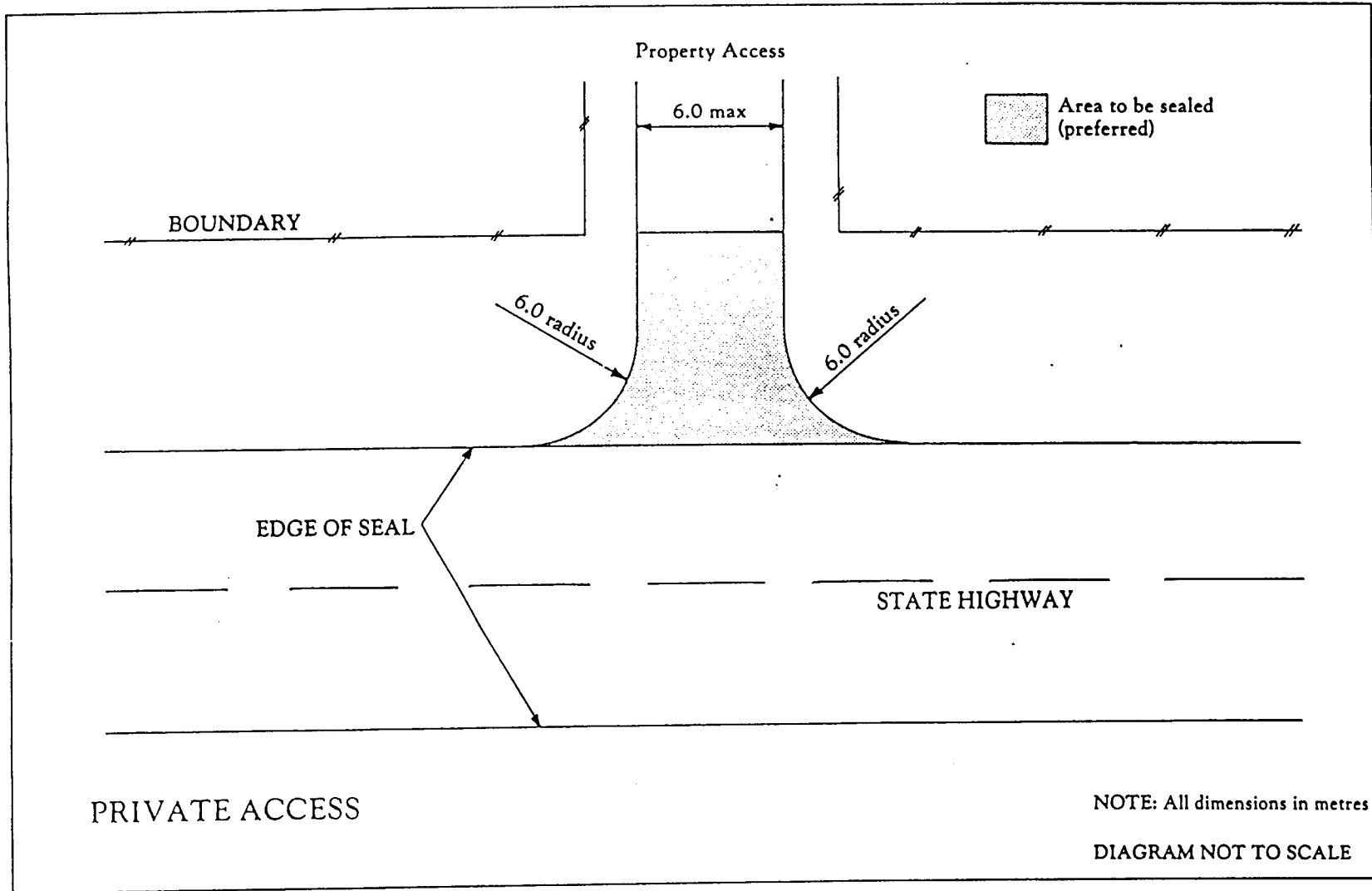

Diagram 2

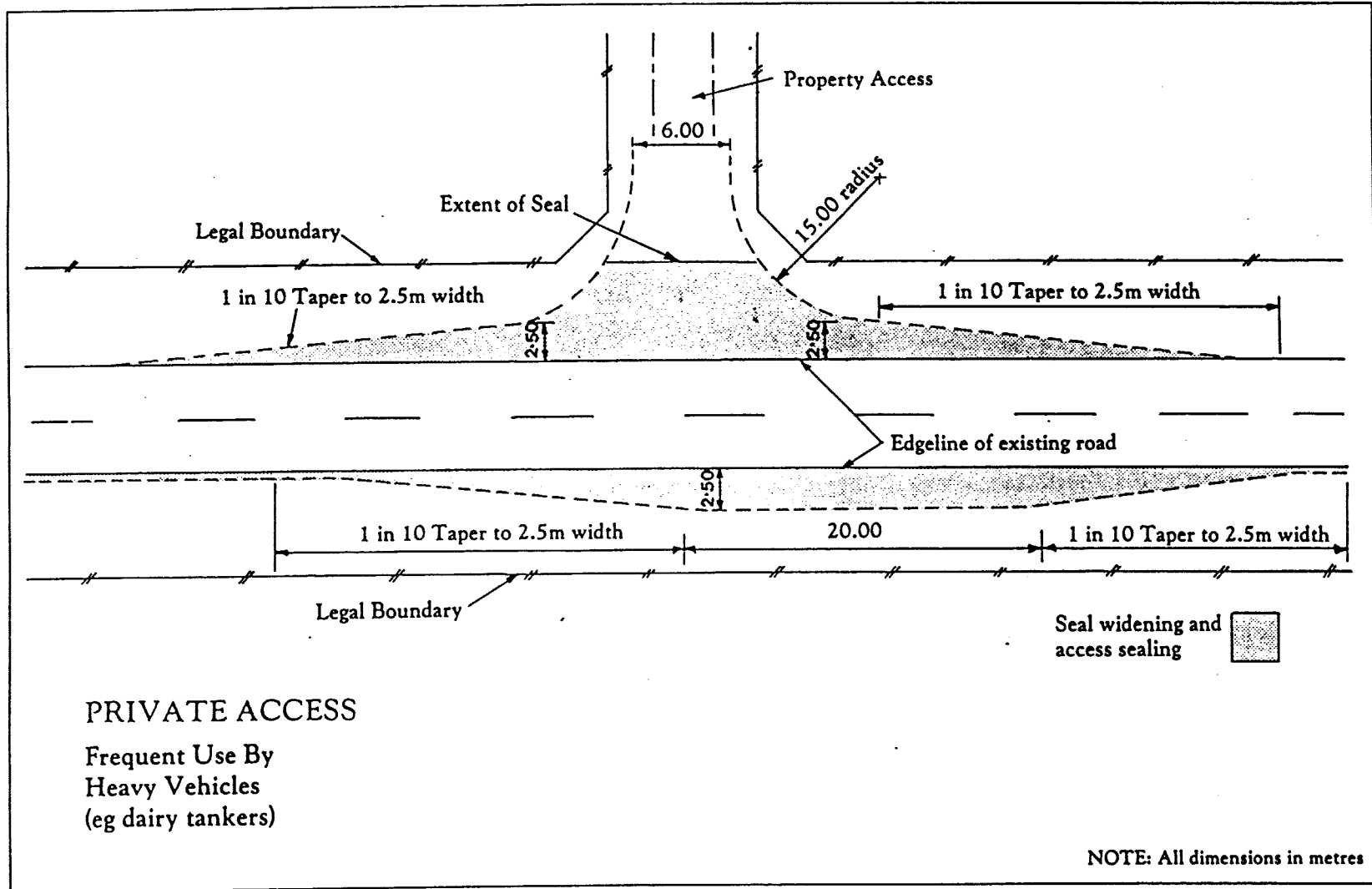

Diagram 3

J. PARKING LOADING AND ACCESS.

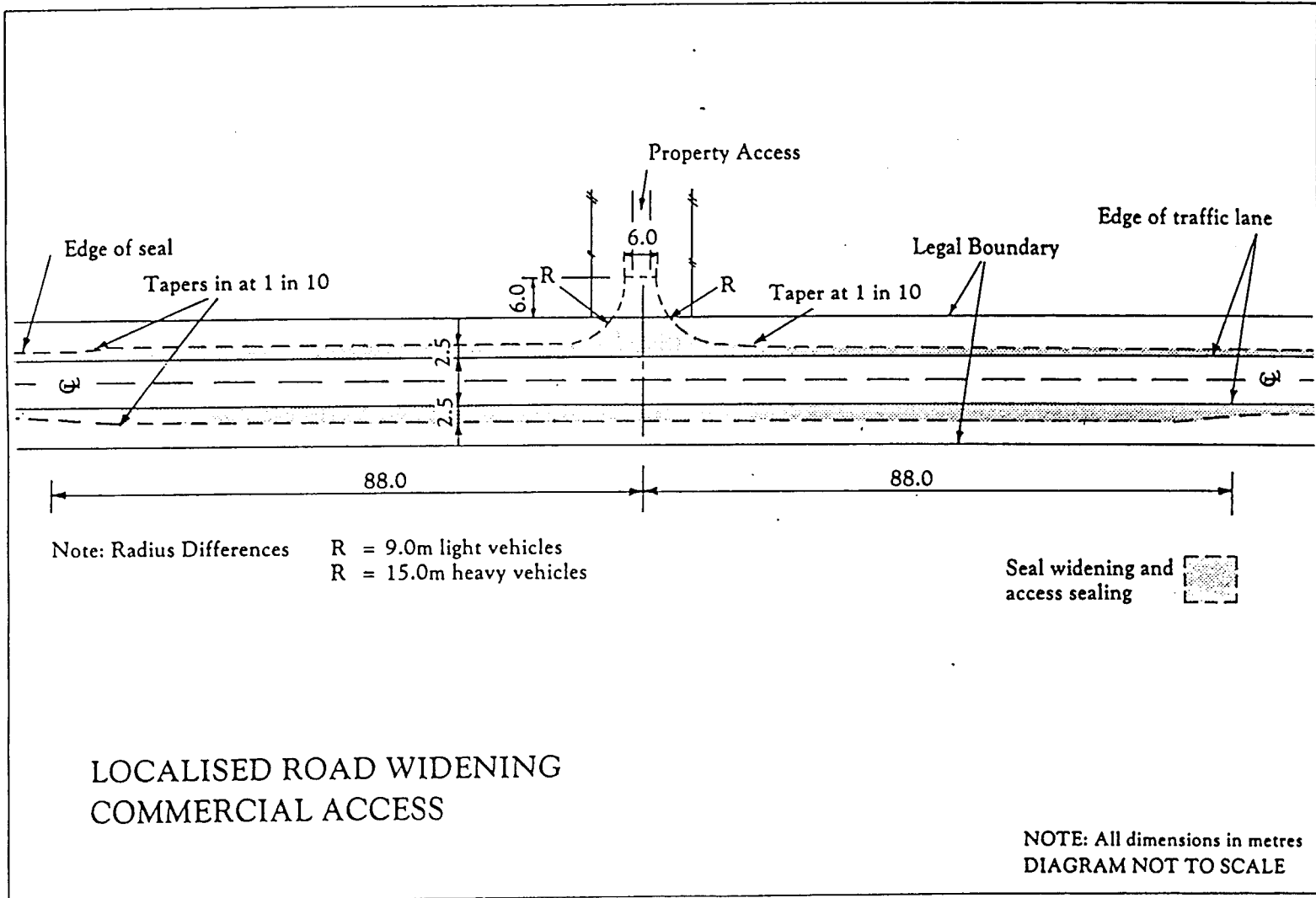

Diagram 4