

150mm
100
50
0 10mm

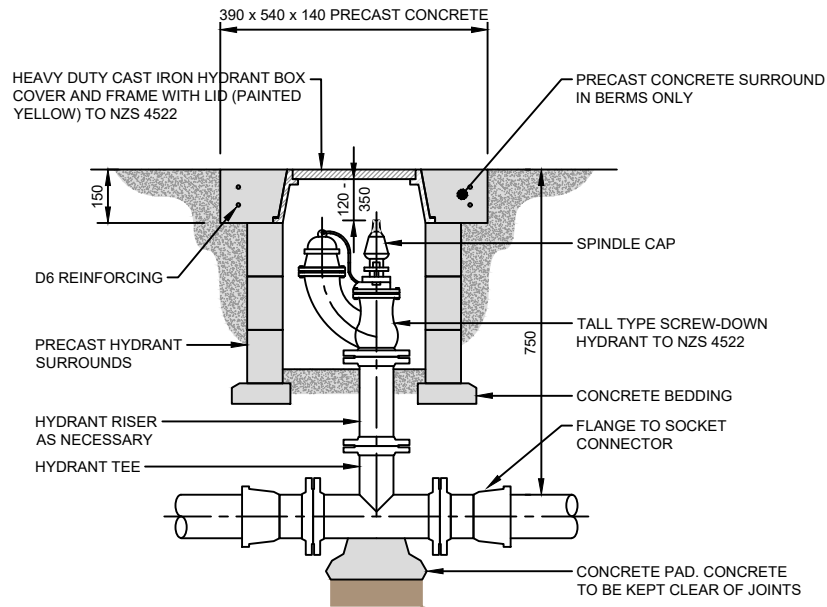

FIRE HYDRANT BOX

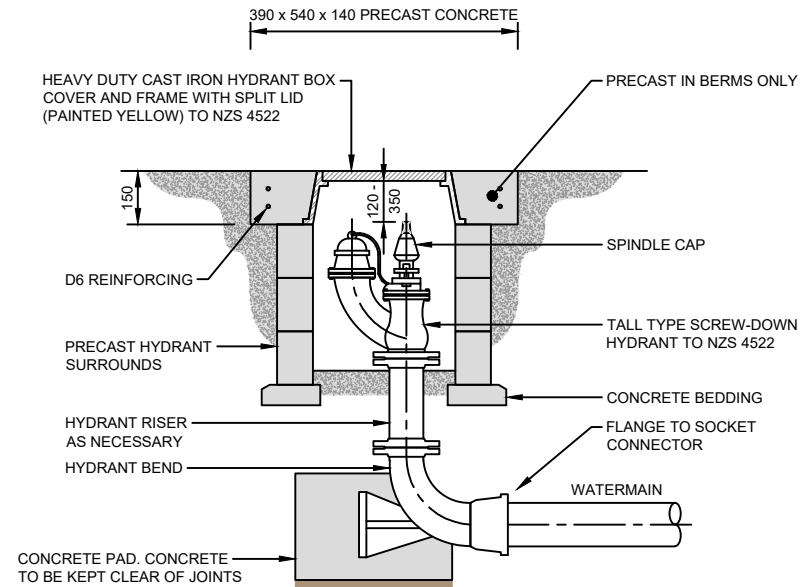

TERMINAL HYDRANT BOX

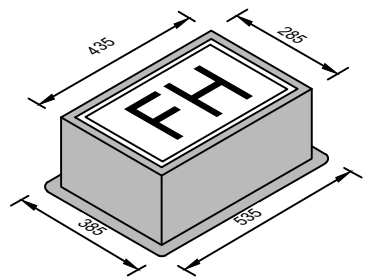

CAST IRON LID
TO BE USED IN FOOTPATHS,
VEHICLE CROSSINGS &
CARRIAGEWAYS

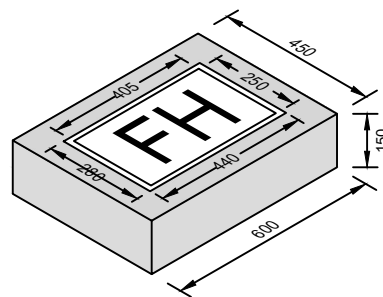

PRECAST CONCRETE CI LID
BERM USE ONLY

NOTE:

1. ALL DIMENSIONS IN MILLIMETRES.
2. DEPTH OF MAIN 750mm COVER.
3. DIMENSIONS DEPENDANT ON SUPPLIER.



STANDARD DETAILS

**MAINS AND RIDER MAINS
FIRE HYDRANTS**

Drawn	Designed	
A. KOCHAR	J. SAXTON	
Approved	Revision Date	
M. COLE	APRIL 2021	
Scale	Drawing No.	Revision
NOT TO SCALE	KCDC-WS-008	R4