

150mm
100
50
10mm
0

PVC PIPE SN16 TO PRIVATE PROPERTY BOUNDARY (OR CONNECT TO EXISTING).

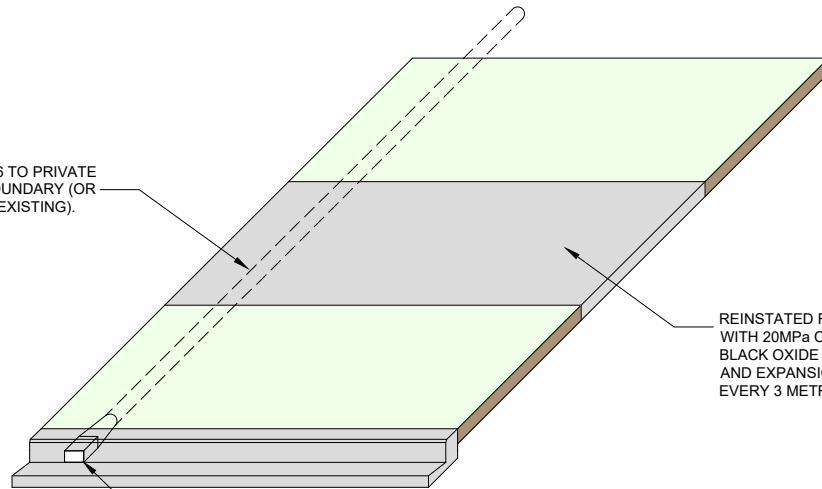

REINSTATED FOOTPATH WITH 20MPa CONCRETE BLACK OXIDE (1KG PER M3) AND EXPANSION JOINTS EVERY 3 METRES.

PREGALV RECTANGULAR TO CIRCULAR STORMWATER KERB ADAPTOR

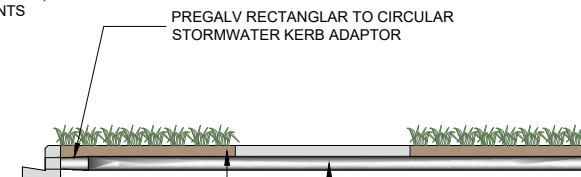

MIN COVER 75mm

SN16 PVC PIPE TO PRIVATE BOUNDARY (OR CONNECT TO EXISTING).

2x D10 REBAR DRILLED / EPOXIED INTO EXISTING KERB

600mm

KERB FACE

* CUT 600mm OUT OF KERB, IF NOT INSTALLING DURING KERB FORMATION. REINSTATE KERB INSTALLING 2x D10 REBAR AND CONCRETE WITH MATCHING FINISH TO KERB.



EXISTING KERB FACE

KERB FACE
CONCRETE

MIN COVER 75mm

INVERT OF EXISTING CHANNEL



STANDARD DETAILS

ROADING STANDARDS
STORMWATER OUTLET ON KERB AND CHANNEL

Drawn	Designed	
J. GOODMAN		
Approved	Revision Date	
G. O'CONNOR	OCTOBER 2020	
Scale	Drawing No.	Revision
NOT TO SCALE	KCDC-RD-012	R5